

"SOLUTION" 1500 Machine Nozzles And Options

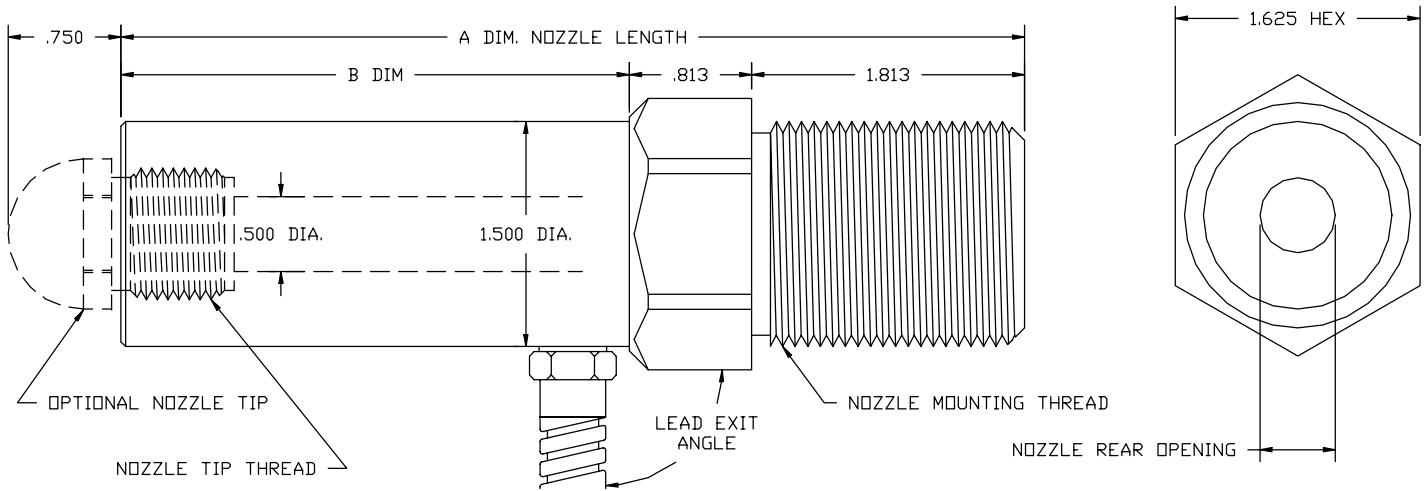

How To Order - Select the desired nozzle from the stock list in the right hand column. Standard items conform to the drawing above. To order, replace standard option codes in the product number with your option codes selected from the tables below. Order the optional thermocouple as a separate line item on your order. Standard components are designed for 240 volt operation. Special voltage or wattage ratings can be supplied if required. Nozzle tips are not supplied with the nozzle but can be ordered as a separate item from the stock lists at the lower right corner.

Product Number	A Dim.	B Dim.	Watts
MNA-1500-5.00-B50A90	5.000	2.375	535
MNA-1500-6.00-B50A90	6.000	3.375	655
MNA-1500-7.00-B50A90	7.000	4.375	770
MNA-1500-8.00-B50A90	8.000	5.375	890
MNA-1500-9.00-B50A90	9.000	6.375	1005
MNA-1500-10.00-B50A90	10.000	7.375	1125
MNA-1500-11.00-B50A90	11.000	8.375	1240
MNA-1500-12.00-B50A90	12.000	9.375	1360
MNA-1500-13.00-B50A90	13.000	10.375	1480
MNA-1500-14.00-B50A90	14.000	11.375	1595

MN A - 1500 - 5.00 - B 50 A90

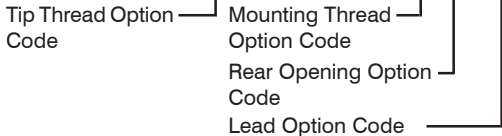

Tip Thread Options	Availability	Option Code
Standard 7/8-14 UNF	Stock	A

Mounting Thread Options	Availability	Option Code
1 1/4-12 Thread	Stock	A
1 1/2-12 Thread	Stock	B
1 3/4-8 Thread	Stock	C

Rear Opening Options	Availability	Option Code
.50 Diameter Rear Opening	Stock	50
.75 Diameter Rear Opening	Stock	75

Lead Exit Options	Availability	Option Code
Armor And Leads @ 90 Deg.	Stock	A90
Armor And Leads @ 45 Deg.	Stock	A45

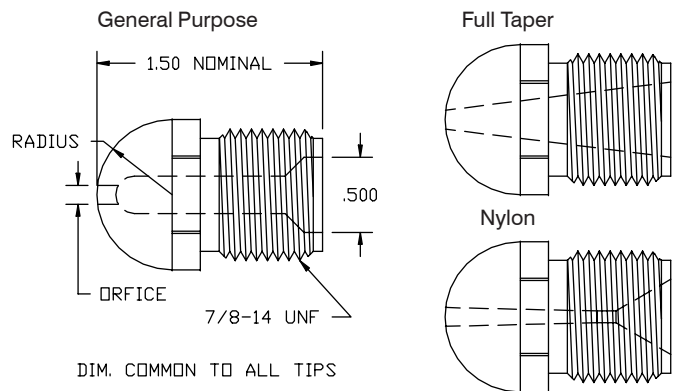

Type	Radius	.125 Orifice	.187 Orifice	.250 Orifice
General Purpose	.50	NTG50-125	NTG50-187	NTG50-250
	.75	NTG75-125	NTG75-187	NTG75-250
Full Taper	.50	NTT50-125	NTT50-187	NTT50-250
	.75	NTT75-125	NTT75-187	NTT75-250
Nylon	.50	NTN50-125	NTN50-187	NTN50-250
	.75	NTN75-125	NTN75-187	NTN75-250