

“SOLUTION” Thermal Spike Valve Torpedoes.....For Precise And Reliable Valve Gating

In addition to a thermocouple controlled body heater, thermally coordinated to the actual mold environment to maintain optimum resin temperature, the "SOLUTION" low voltage torpedoes feature an independent spike tip heater that provides a precision gate valve function.

The valve action is accomplished by turning the spike tip element on and off in a timed sequence synchronized to the processing cycle mold opening action. Mold opening initiates a time delayed tip element activation. Activation of the tip element rapidly heats the resin in the gate area to the required melt temperature for injection. During or immediately after injection the tip heating element is deactivated. At the completion of part filling the resin in the gate rapidly cools, allowing the part to be cleanly separated from the solidified or semi solidified resin in the gate as the mold opens. The thermal spike valve torpedoes provide cosmetically clean gate marks while eliminating stringing and drooling at the gate.

Heating elements of the “SOLUTION” Thermal Spike Valve Torpedoes are embedded in ceramic compacted to near theoretical density for optimum heat transfer and insulation dielectric. The densely compacted assembly maximizes performance and reliability and provides total resistance to vibration, shock and physical abuse. The rapid transfer of heat from the element to the tip substantially improves heating and cooling rates in the critical tip and gate area and permits the use of higher tip heat settings. The tip heating rate exceeds 200° F. per second with gate opening time only limited by resin thermal properties, gate configuration and cavity temperature.

“SOLUTION” Thermal Spike Valve Torpedoes feature a built-in thermowell equipped with a removable type “K” mineral insulated thermocouple. The removal feature permits the use of alternate calibration and junction types as well as providing for the replacement of damaged thermocouples. The low maintenance construction is available in range of materials satisfying the needs of both general purpose and engineering grade resins and also features replaceable power leads and a repairable tip. The integral heated "SOLUTION" Thermal Spike Valve Torpedo is an incredibly compact, high strength torpedo capable of reliable performance under the most severe operating conditions. The high performance construction improves process cycle, reduces down time and provides extended torpedo service life for more cost effective molding.

Duratherm is currently manufacturing the precision thermal spike valve components in configurations and power ratings suitable for direct replacement of existing thermal valve gating torpedoes as well as new hot runner and insulated runner valve gating applications. Companion accessories including stainless steel o-rings and closed-loop control systems designed for use with the thermal spike valve torpedoes are also available. Our exclusive integral heated torpedo construction in combination with the thermal spike tip heater provides performance, reliability and precision gating for single sprue, multi-drop hot manifold and insulated runner applications.

1

Thermal Spike Valve Action. The independent tip heating element activation is synchronized to the molding process and cycles on and off to provide precision valve gating. Compacted ceramic insulated construction maximizes heat transfer providing tip heating rates in excess of 200° F. per second while maintaining optimum element reliability.

2

Reliable Integral Heated Design. Our swaged, integral heated construction insures maximum heat transfer efficiency. Both body and tip elements feature welded connections for optimum performance. The body element is CNC machine wound to precise gauge and pitch requirements. The tip element is precision ground to control tip element resistance and heating characteristics.

3

Optimum Heat Profile. “Solution” thermal spike valve torpedoes feature body elements thermally coordinated to the processing environment. All torpedoes have been designed for in-process temperature uniformity and have been tested in the actual mold environment for conformance to our strict standards. This thermally coordinated heat profile provides heat uniformity throughout the torpedo body and optimizes tip area temperature for proper thermal spike valve operation.

4

High Temperature Design. Our thermally efficient element construction allows increased tip wattage while increasing tip element reliability. The "SOLUTION" thermal spike valve torpedo provides tip heating performance surpassing all other thermal valve style torpedoes.

5

Superior Temperature Control. A formed tube style thermowell allows the use of a replaceable, mineral insulated thermocouple in the standard grounded junction type "K" calibration or optional grounded and ungrounded junction styles in any desired thermocouple calibration. The quality thermocouple and its ideal sensing location provide precise control of torpedo body and resin melt temperatures.

6

Rugged Lead Systems. External leads are securely attached to the internal conductors of the torpedo heating elements. Standard ground leads are internally connected and exit with power leads. External ground leads using the screw style torpedo body mounting are also available at no extra cost. The lead terminations are designed for abuse resistance and repairability. While sleeve style lead protection is standard armor or wire braid protection can also be added for additional resistance to mechanical abuse.

"SOLUTION" Thermal Spike Valve Torpedoes

7

Standard Voltage And Power Ratings. Spike valve torpedoes feature standard 11 volt tip rating and 32 volt body rating to maintain compatability with existing controls. Tip element configuration dictates use of low voltage but modified element designs can be implimented to further increase tip power output. Body voltage ratings to 240 volts and increased body power ratings are available when required.

9

Extended Range Of Standard Components. Standard torpedoes include configurations and power ratings suitable for direct replacement of existing thermal valving components. Our complete selection of thermal spike valve torpedoes includes hot runner and insulated runner component styles.

8

Low Maintenance And Repairable. Improved heating characteristics and solid head design eliminates leakage within the system. Internally connected ground wires eliminates connection problems associated with screw ground connection methods. Most physical damage to the torpedo or tip can be repaired. Duratherm provides full service repair of the torpedo, leads and thermocouple.

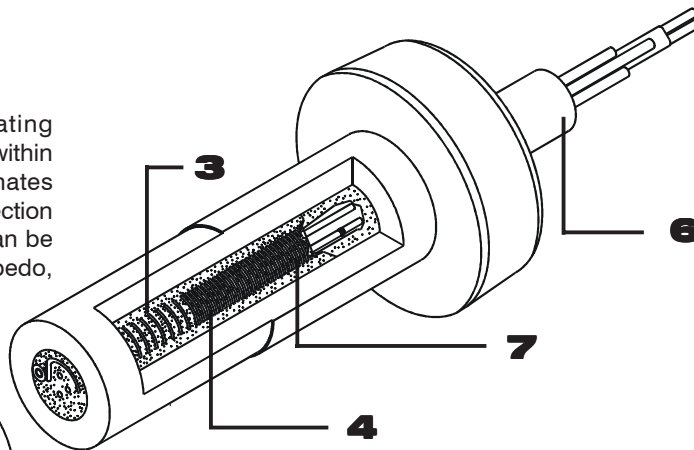
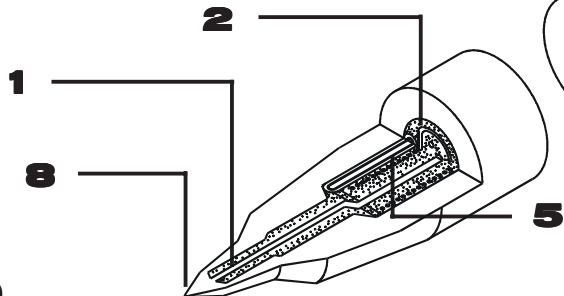

U.S. and foreign patents pending.

10

Versatile Design And Construction. The "SOLUTION" thermal spike valve can be implemented in most torpedo configurations including multiple tip styles. A variety of tip style sprue and manifold bushings can also utilize the thermal spike tip design. Modified standard or total custom torpedo designs featuring the thermal spike valve are readily manufactured to customer specifications.

12

Premium Heat-treated Tool Steel. Standard torpedoes are machined from AISI H13 tool steel and hardened to 54-56 RC. Other tool steel type and/or special coatings can be supplied to meet the requirements of glass and mineral filled resins.

11

Machined To Precision Dimensions. "SOLUTION" torpedoes are machined to precision tolerances using both CNC turning and precision grinding operations. Each torpedo is subjected to a rigorous final inspection process prior to shipment.

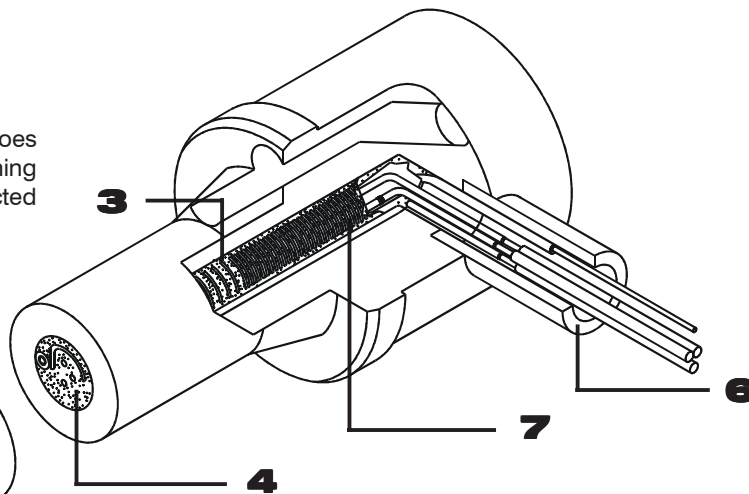
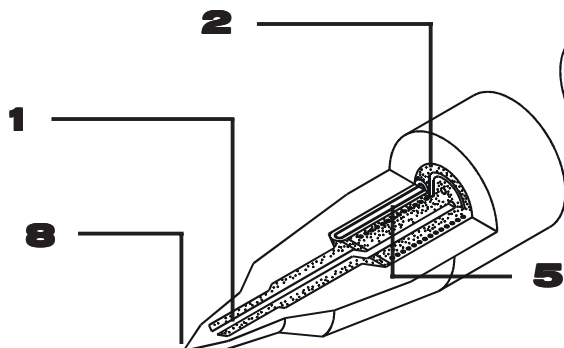

U.S. and foreign patents pending.