

"SOLUTION" 250 Gating Torpedoes And Options

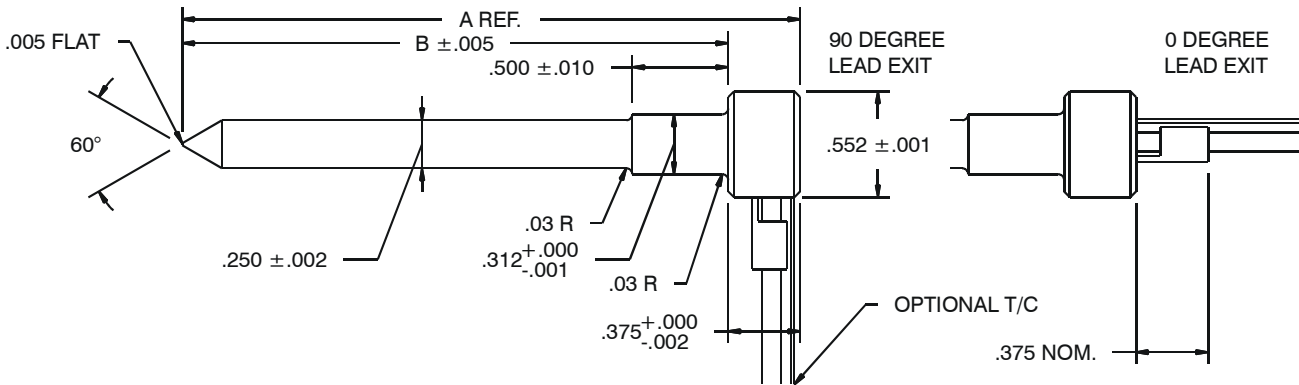

Heat Profile Options	Availability	Option Code
Insulated Runner Heat Profile	Stock	I
Hot Runner Heat Profile	Manufacture	H

Tip Options	Availability	Option Code
Single 60 Degree Tip	Stock	S
Double 30/60 Degree Tip	Stock	D
Radius 40/90 Degree Tip	Manufacture	R

How To Order - Select the desired torpedo from the stock list below. Standard items conform to the drawing above. To order, replace standard option codes in the product number with the option codes of your choice. Order the optional thermocouple as a separate line item on your order. Standard components are designed for 240 volt operation. Special voltage or wattage ratings can be supplied if required.

G S I - 250 - 3.22 - A 90

Tip Option Code ————
Heat Option Code ————
Lead Option Code ————
Head Option Code ————

Product Number	A Dim.	B Dim.	Watts
GSI-250-2.22-A90	2.22	1.845	55
GSI-250-2.72-A90	2.72	2.345	70
GSI-250-3.22-A90	3.22	2.845	85
GSI-250-3.72-A90	3.72	3.345	100
GSI-250-4.22-A90	4.22	3.845	115
GSI-250-4.72-A90	4.72	4.345	135

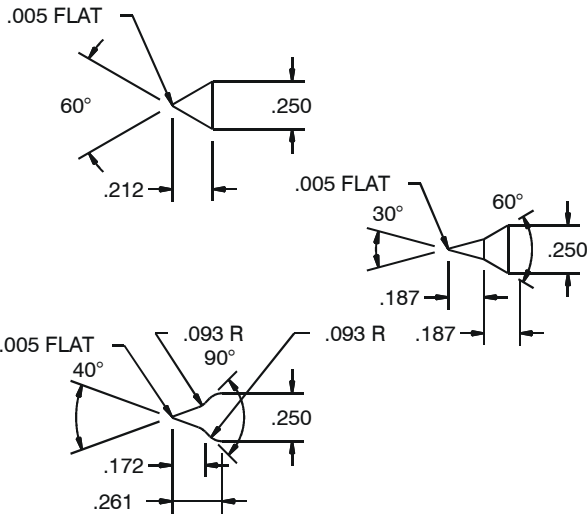

Head Diameter Options	Availability	Option Code
.552 Diameter +/- .001	Stock	A

Lead Exit Options	Availability	Option Code
Right Angle 90 Deg. Lead Exit	Stock	90
Straight Out 0 Deg. Lead Exit	Stock	00

"SOLUTION" 312 Gating Torpedoes And Options

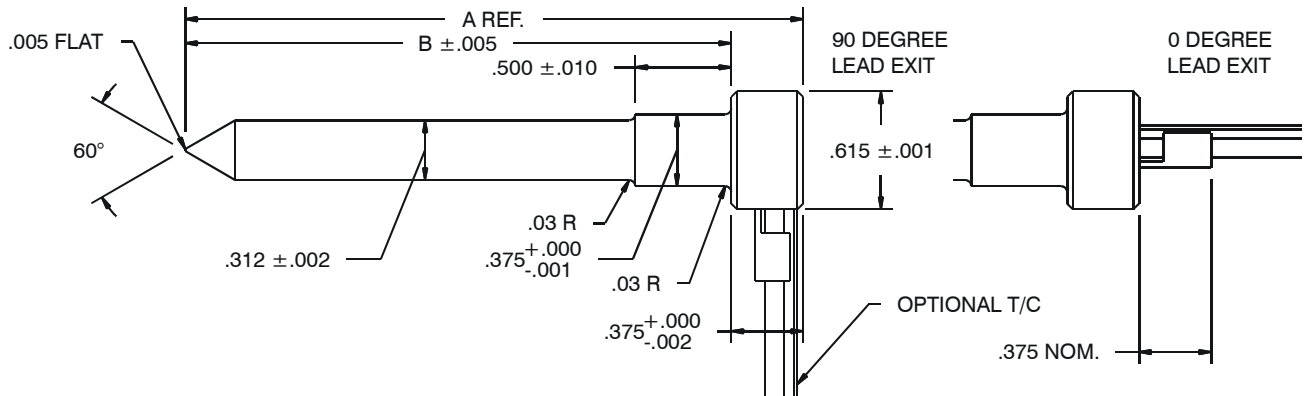

Heat Profile Options	Availability	Option Code
Insulated Runner Heat Profile	Stock	I
Hot Runner Heat Profile	Manufacture	H

Tip Options	Availability	Option Code
Single 60 Degree Tip	Stock	S
Double 30/60 Degree Tip	Stock	D
Radius 40/90 Degree Tip	Manufacture	R

How To Order - Select the desired torpedo from the stock list below. Standard items conform to the drawing above. To order, replace standard option codes in the product number with the option codes of your choice. Order the optional thermocouple as a separate line item on your order. Standard components are designed for 240 volt operation. Special voltage or wattage ratings can be supplied if required.

G S I - 312 - 3.22 - A 90

Tip Option Code | | | |
 Heat Option Code | | | |

Product Number	A Dim.	B Dim.	Watts
GSI-312-2.22-A90	2.22	1.845	65
GSI-312-2.72-A90	2.72	2.345	85
GSI-312-3.22-A90	3.22	2.845	105
GSI-312-3.72-A90	3.72	3.345	125
GSI-312-4.22-A90	4.22	3.845	145
GSI-312-4.72-A90	4.72	4.345	165

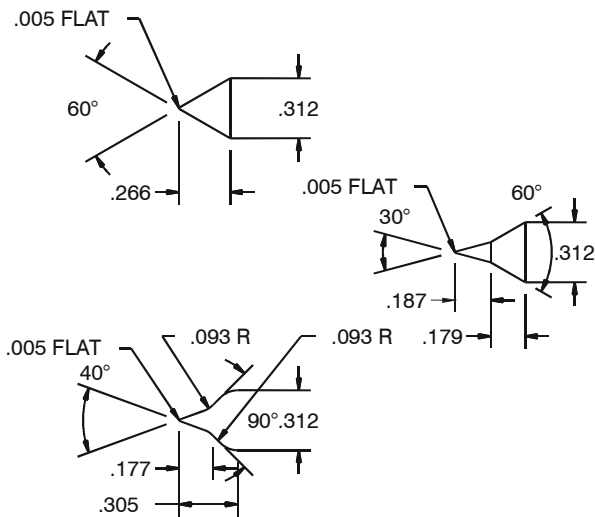

Metric Fit Conversion Option - This option modifies the fit to a 10 mm (.394) diameter by .625 long and the head to .740 diameter. This modification simplifies conversion of competitive components with similar dimensions. To order, specify a head option of "M" in the product code.

Head Diameter Options	Availability	Option Code
.615 Diameter +/- .001	Stock	A

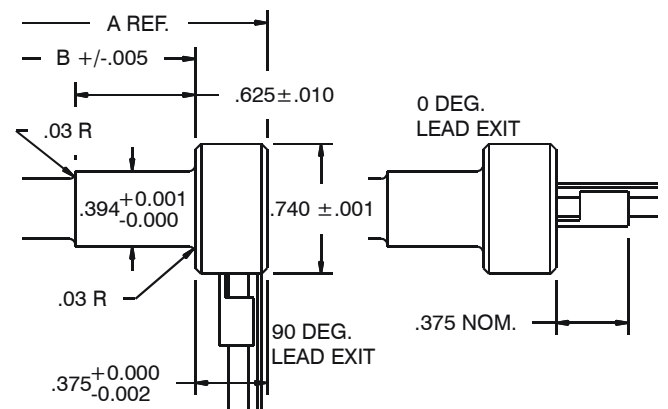

Lead Exit Options	Availability	Option Code
Right Angle 90 Deg. Lead Exit	Stock	90
Straight Out 0 Deg. Lead Exit	Stock	00

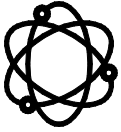

"SOLUTION" 394 Gating Torpedoes And Options

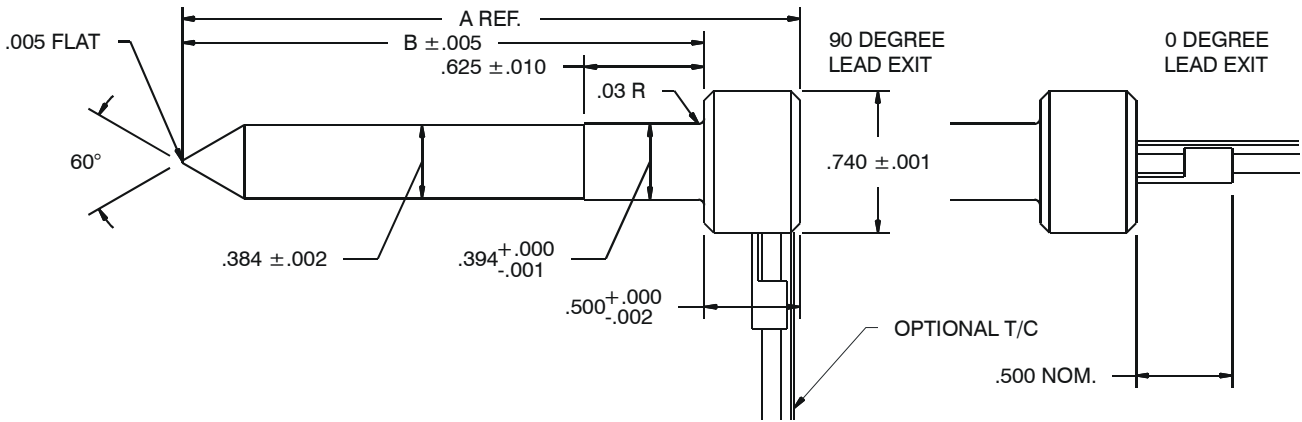

Heat Profile Options	Availability	Option Code
Insulated Runner Heat Profile	Stock	I
Hot Runner Heat Profile	Manufacture	H

Tip Options	Availability	Option Code
Single 60 Degree Tip	Stock	S
Double 30/60 Degree Tip	Stock	D
Radius 40/90 Degree Tip	Manufacture	R
Tunnel Flat Blank Tip	Manufacture	T

How To Order - Select the desired torpedo from the stock list below. Standard items conform to the drawing above. To order, replace standard option codes in the product number with the option codes of your choice. Order the optional thermocouple as a separate line item on your order. Standard components are designed for 240 volt operation. Special voltage or wattage ratings can be supplied if required.

G S I - 394 - 3.22 - A 90

Tip Option Code | Heat Option Code | | Lead Option Code | Head Option Code

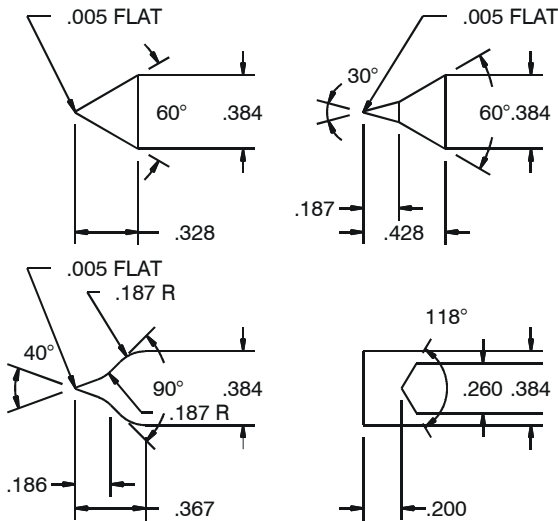

Head Diameter Options	Availability	Option Code
.740 Diameter +/- .001	Stock	A
.720 Diameter +/- .001	Stock	B
.677 Diameter +/- .001	Stock	C

Lead Exit Options	Availability	Option Code
Right Angle 90 Deg. Lead Exit	Stock	90
Straight Out 0 Deg. Lead Exit	Stock	00

Product Number	A Dim.	B Dim.	Watts
GSI-394-3.22-A90	3.22	2.72	135
GSI-394-3.72-A90	3.72	3.22	160
GSI-394-4.22-A90	4.22	3.72	185
GSI-394-4.72-A90	4.72	4.22	210
GSI-394-5.22-A90	5.22	4.72	235
GSI-394-5.72-A90	5.72	5.22	260
GSI-394-6.22-A90	6.22	5.72	285
GSI-394-6.72-A90	6.72	6.22	310
GSI-394-7.22-A90	7.22	6.72	335
GSI-394-7.72-A90	7.72	7.22	355
GSI-394-8.22-A90	8.22	7.72	380
GSI-394-8.72-A90	8.72	8.22	405

"SOLUTION" 500 Gating Torpedoes And Options

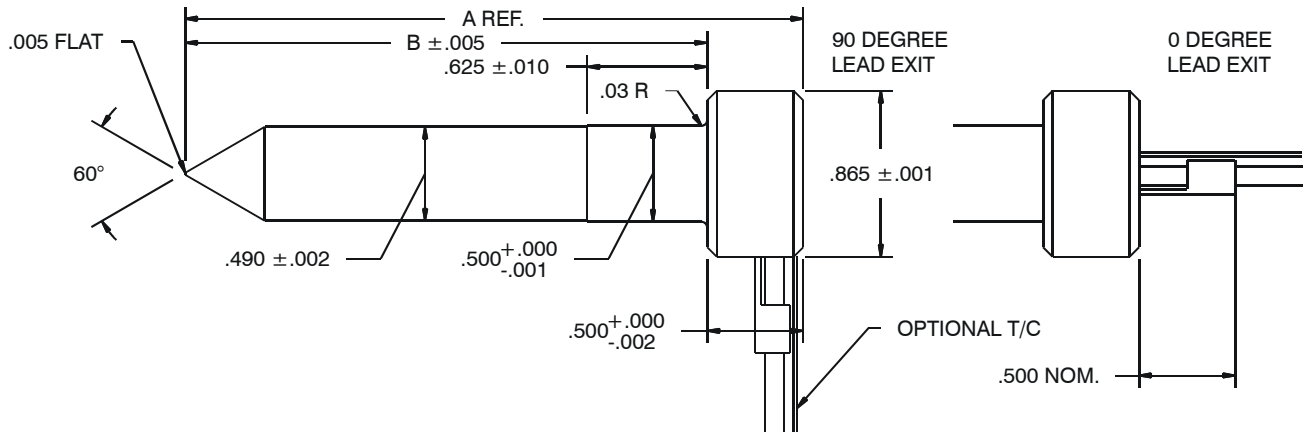

Heat Profile Options	Availability	Option Code
Insulated Runner Heat Profile	Stock	I
Hot Runner Heat Profile	Manufacture	H

Tip Options	Availability	Option Code
Single 60 Degree Tip	Stock	S
Double 30/60 Degree Tip	Stock	D
Radius 40/90 Degree Tip	Manufacture	R
Tunnel Flat Blank Tip	Manufacture	T

How To Order - Select the desired torpedo from the stock list below. Standard items conform to the drawing above. To order, replace standard option codes in the product number with the option codes of your choice. Order the optional thermocouple as a separate line item on your order. Standard components are designed for 240 volt operation. Special voltage or wattage ratings can be supplied if required.

G S I - 500 - 3.22 - A 90

Tip Option Code Lead Option Code
Heat Option Code Head Option Code

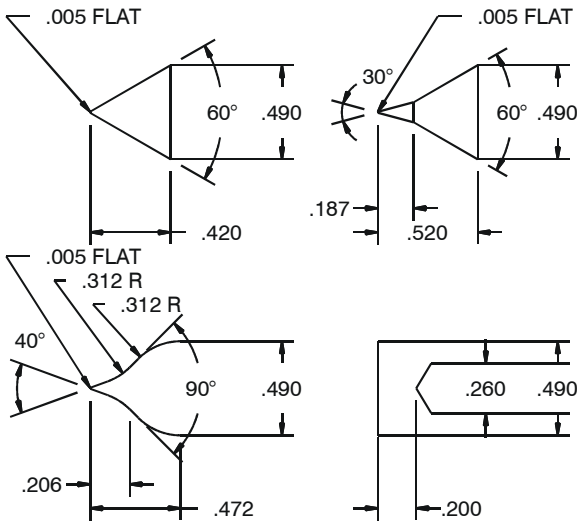

Head Diameter Options	Availability	Option Code
.865 Diameter +/- .001	Stock	A
.740 Diameter +/- .001	Stock	B
.720 Diameter +/- .001	Stock	C

Product Number	A Dim.	B Dim.	Watts
GSI-500-3.22-A90	3.22	2.72	170
GSI-500-3.72-A90	3.72	3.22	200
GSI-500-4.22-A90	4.22	3.72	235
GSI-500-4.72-A90	4.72	4.22	265
GSI-500-5.22-A90	5.22	4.72	295
GSI-500-5.72-A90	5.72	5.22	330
GSI-500-6.22-A90	6.22	5.72	360
GSI-500-6.72-A90	6.72	6.22	390
GSI-500-7.22-A90	7.22	6.72	420
GSI-500-7.72-A90	7.72	7.22	455
GSI-500-8.22-A90	8.22	7.72	485
GSI-500-8.72-A90	8.72	8.22	515
GSI-500-9.22-A90	9.22	8.72	550
GSI-500-9.72-A90	9.72	9.22	580
GSI-500-10.22-A90	10.22	9.72	610
GSI-500-10.72-A90	10.72	10.22	640

Lead Exit Options	Availability	Option Code
Right Angle 90 Deg. Lead Exit	Stock	90
Straight Out 0 Deg. Lead Exit	Stock	00

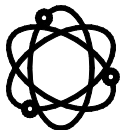

"SOLUTION" 625 Gating Torpedoes And Options

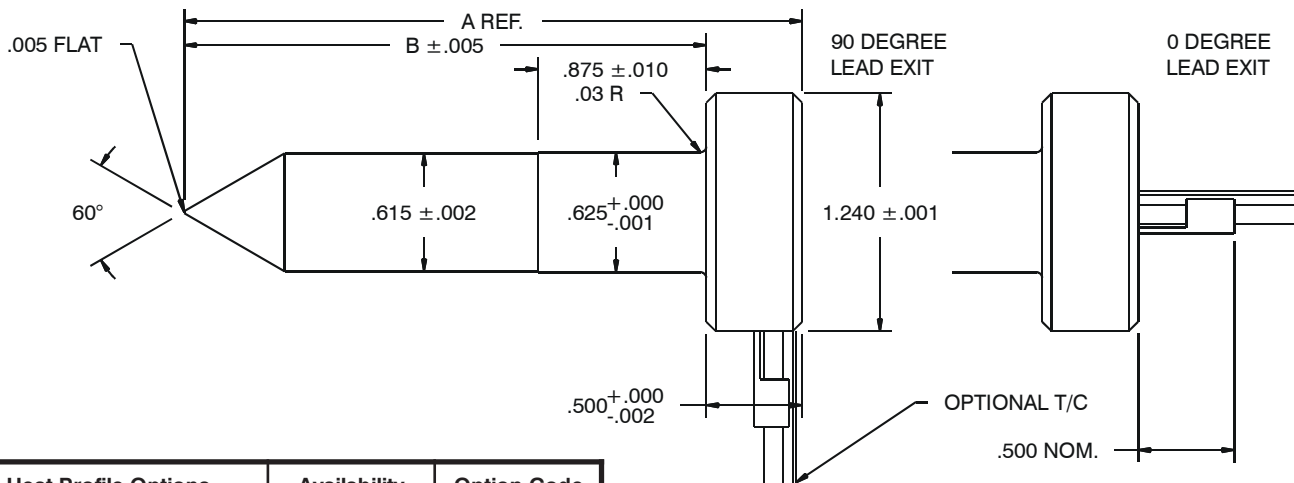

Heat Profile Options	Availability	Option Code
Insulated Runner Heat Profile	Stock	I
Hot Runner Heat Profile	Manufacture	H

Tip Options	Availability	Option Code
Single 60 Degree Tip	Stock	S
Double 30/60 Degree Tip	Stock	D
Radius 40/90 Degree Tip	Manufacture	R
Tunnel Flat Blank Tip	Manufacture	T

How To Order - Select the desired torpedo from the stock list below. Standard items conform to the drawing above. To order, replace standard option codes in the product number with the option codes of your choice. Order the optional thermocouple as a separate line item on your order. Standard components are designed for 240 volt operation. Special voltage or wattage ratings can be supplied if required.

G S I - 625 - 3.22 - A 90

Tip Option Code → Lead Option Code →
 Heat Option Code → Head Option Code →

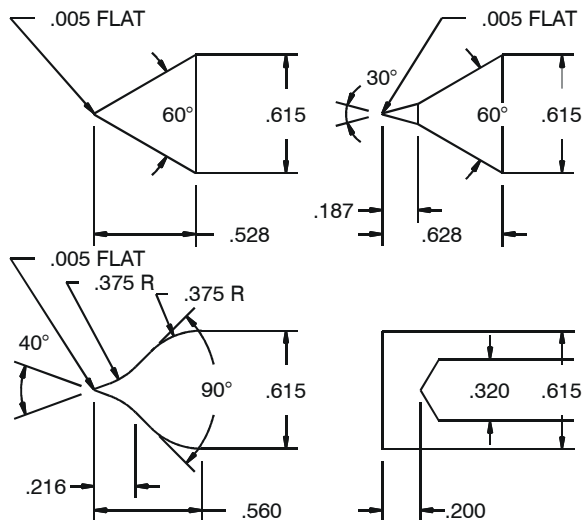

Head Diameter Options	Availability	Option Code
1.240 Diameter +/- .001	Stock	A
.970 Diameter +/- .001	Stock	B

Product Number	A Dim.	B Dim.	Watts
GSI-625-3.22-A90	3.22	2.72	215
GSI-625-3.72-A90	3.72	3.22	255
GSI-625-4.22-A90	4.22	3.72	290
GSI-625-4.72-A90	4.72	4.22	330
GSI-625-5.22-A90	5.22	4.72	370
GSI-625-5.72-A90	5.72	5.22	410
GSI-625-6.22-A90	6.22	5.72	450
GSI-625-6.72-A90	6.72	6.22	490
GSI-625-7.22-A90	7.22	6.72	530
GSI-625-7.72-A90	7.72	7.22	565
GSI-625-8.22-A90	8.22	7.72	605
GSI-625-8.72-A90	8.72	8.22	645
GSI-625-9.22-A90	9.22	8.72	685
GSI-625-9.72-A90	9.72	9.22	725
GSI-625-10.22-A90	10.22	9.72	765
GSI-625-10.72-A90	10.72	10.22	805
GSI-625-11.22-A90	11.22	10.72	840
GSI-625-11.72-A90	11.72	11.22	880
GSI-625-12.22-A90	12.22	11.72	920
GSI-625-12.72-A90	12.72	12.22	960

Lead Exit Options	Availability	Option Code
Right Angle 90 Deg. Lead Exit	Stock	90
Straight Out 0 Deg. Lead Exit	Stock	00

"SOLUTION" 750 Gating Torpedoes And Options

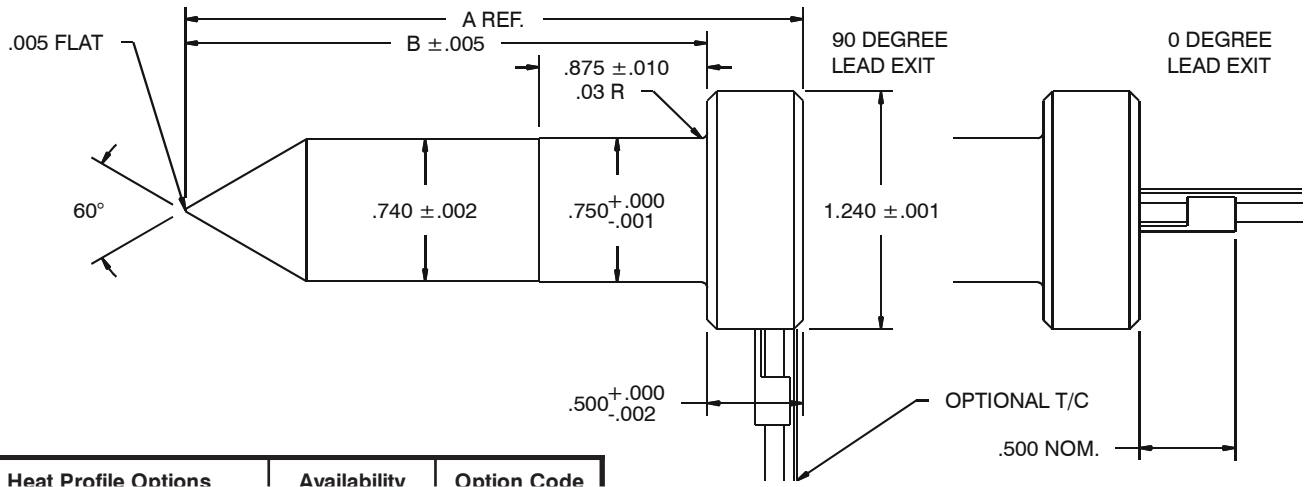

Heat Profile Options	Availability	Option Code
Insulated Runner Heat Profile	Stock	I
Hot Runner Heat Profile	Manufacture	H

Tip Options	Availability	Option Code
Single 60 Degree Tip	Stock	S
Double 30/60 Degree Tip	Stock	D
Radius 40/90 Degree Tip	Manufacture	R
Tunnel Flat Blank Tip	Manufacture	T

How To Order - Select the desired torpedo from the stock list below. Standard items conform to the drawing above. To order, replace standard option codes in the product number with the option codes of your choice. Order the optional thermocouple as a separate line item on your order. Standard components are designed for 240 volt operation. Special voltage or wattage ratings can be supplied if required.

G S I - 750 - 3.22 - A 90

Tip Option Code Lead Option Code
Heat Option Code Head Option Code

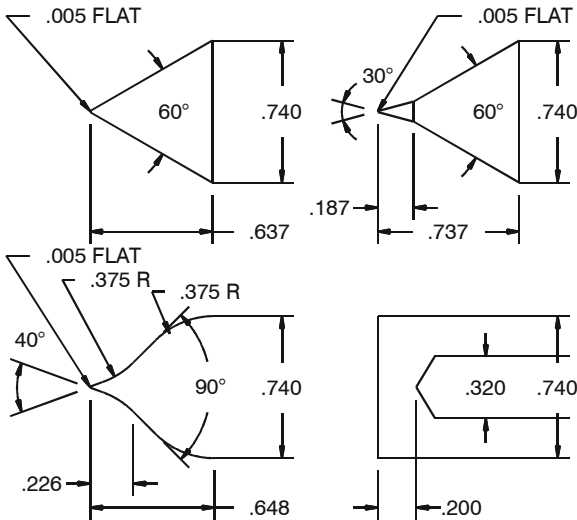

Head Diameter Options	Availability	Option Code
1.240 Diameter +/- .001	Stock	A
.970 Diameter +/- .001	Stock	B

Product Number	A Dim.	B Dim.	Watts
GSI-750-3.22-A90	3.22	2.72	255
GSI-750-3.72-A90	3.72	3.22	305
GSI-750-4.22-A90	4.22	3.72	350
GSI-750-4.72-A90	4.72	4.22	400
GSI-750-5.22-A90	5.22	4.72	445
GSI-750-5.72-A90	5.72	5.22	490
GSI-750-6.22-A90	6.22	5.72	540
GSI-750-6.72-A90	6.72	6.22	585
GSI-750-7.22-A90	7.22	6.72	635
GSI-750-7.72-A90	7.72	7.22	680
GSI-750-8.22-A90	8.22	7.72	730
GSI-750-8.72-A90	8.72	8.22	775
GSI-750-9.22-A90	9.22	8.72	820
GSI-750-9.72-A90	9.72	9.22	870
GSI-750-10.22-A90	10.22	9.72	915
GSI-750-10.72-A90	10.72	10.22	965
GSI-750-11.22-A90	11.22	10.72	1010
GSI-750-11.72-A90	11.72	11.22	1055
GSI-750-12.22-A90	12.22	11.72	1105
GSI-750-12.72-A90	12.72	12.22	1150

Lead Exit Options	Availability	Option Code
Right Angle 90 Deg. Lead Exit	Stock	90
Straight Out 0 Deg. Lead Exit	Stock	00

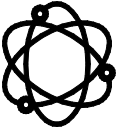

"SOLUTION" 875 Gating Torpedoes And Options

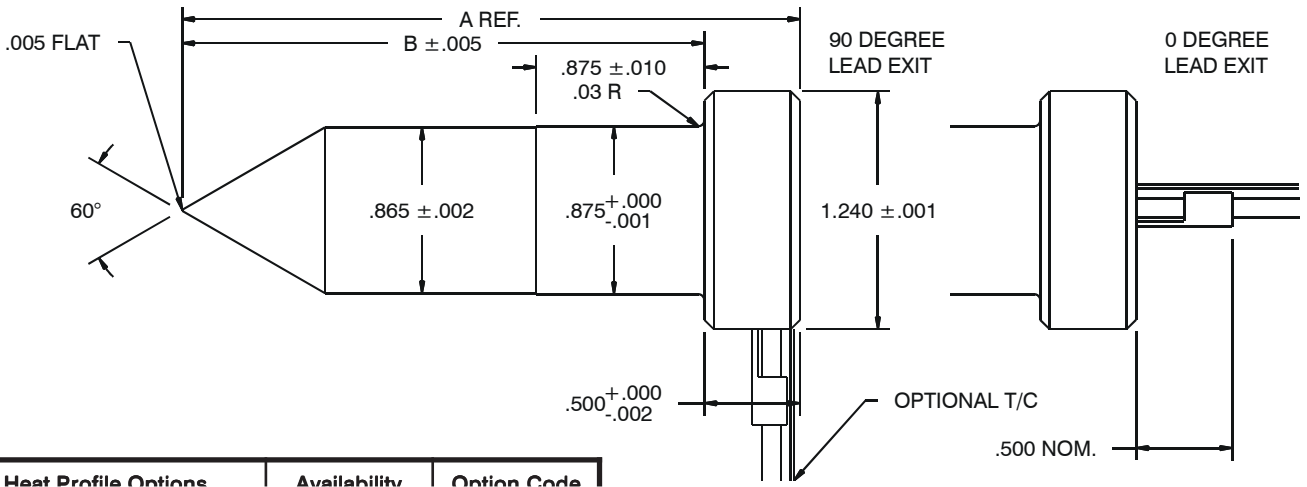

Heat Profile Options	Availability	Option Code
Insulated Runner Heat Profile	Stock	I
Hot Runner Heat Profile	Manufacture	H

Tip Options	Availability	Option Code
Single 60 Degree Tip	Stock	S
Double 30/60 Degree Tip	Stock	D
Radius 40/90 Degree Tip	Manufacture	R
Tunnel Flat Blank Tip	Manufacture	T

How To Order - Select the desired torpedo from the stock list below. Standard items conform to the drawing above. To order, replace standard option codes in the product number with the option codes of your choice. Order the optional thermocouple as a separate line item on your order. Standard components are designed for 240 volt operation. Special voltage or wattage ratings can be supplied if required.

G S I - 875 - 4.22 - A 90

Tip Option Code ————
Heat Option Code ————
Lead Option Code ————
Head Option Code ————

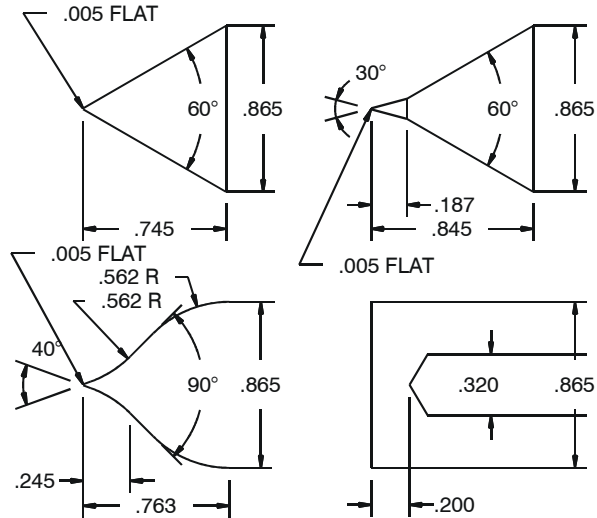

Head Diameter Options	Availability	Option Code
1.240 Diameter +/- .001	Stock	A

Lead Exit Options	Availability	Option Code
Right Angle 90 Deg. Lead Exit	Stock	90
Straight Out 0 Deg. Lead Exit	Stock	00

Product Number	A Dim.	B Dim.	Watts
GSI-875-4.22-A90	4.22	3.72	410
GSI-875-4.72-A90	4.72	4.22	465
GSI-875-5.22-A90	5.22	4.72	520
GSI-875-5.72-A90	5.72	5.22	575
GSI-875-6.22-A90	6.22	5.72	630
GSI-875-6.72-A90	6.72	6.22	685
GSI-875-7.22-A90	7.22	6.72	740
GSI-875-7.72-A90	7.72	7.22	795
GSI-875-8.22-A90	8.22	7.72	850
GSI-875-8.72-A90	8.72	8.22	905
GSI-875-9.22-A90	9.22	8.72	960
GSI-875-9.72-A90	9.72	9.22	1015
GSI-875-10.22-A90	10.22	9.72	1070
GSI-875-10.72-A90	10.72	10.22	1125
GSI-875-11.22-A90	11.22	10.72	1180
GSI-875-11.72-A90	11.72	11.22	1235
GSI-875-12.22-A90	12.22	11.72	1290
GSI-875-12.72-A90	12.72	12.22	1345
GSI-875-13.22-A90	13.22	12.72	1400
GSI-875-13.72-A90	13.72	13.22	1455

"SOLUTION" 1000 Gating Torpedoes And Options

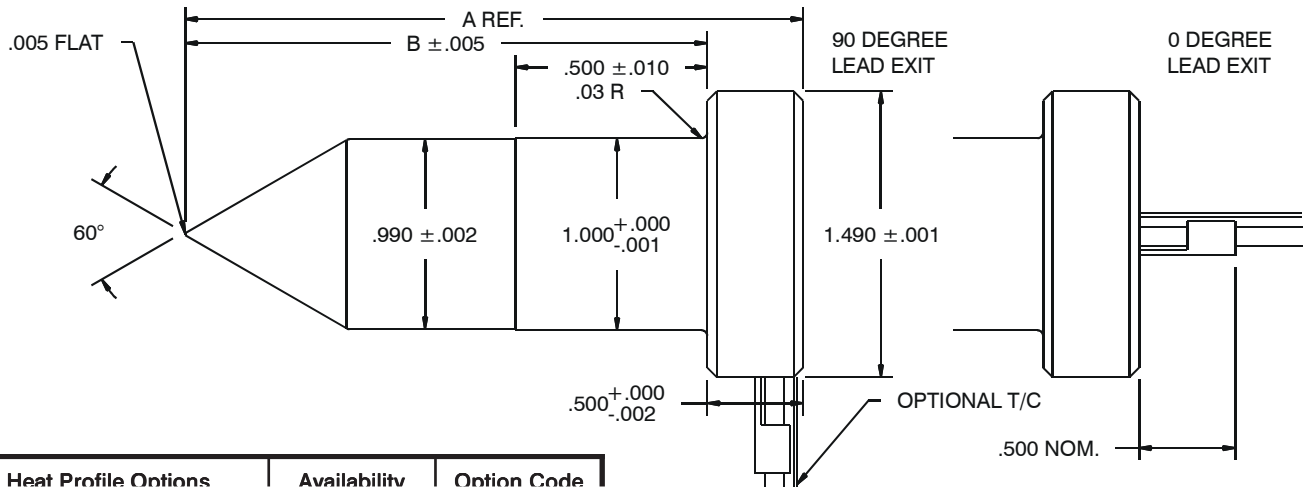

Heat Profile Options	Availability	Option Code
Insulated Runner Heat Profile	Stock	I
Hot Runner Heat Profile	Manufacture	H

Tip Options	Availability	Option Code
Single 60 Degree Tip	Stock	S
Double 30/60 Degree Tip	Stock	D
Radius 40/90 Degree Tip	Manufacture	R
Tunnel Flat Blank Tip	Manufacture	T

How To Order - Select the desired torpedo from the stock list below. Standard items conform to the drawing above. To order, replace standard option codes in the product number with the option codes of your choice. Order the optional thermocouple as a separate line item on your order. Standard components are designed for 240 volt operation. Special voltage or wattage ratings can be supplied if required.

G S I - 1000 - 4.22 - A 90

Tip Option Code Lead Option Code
HeatOption Code Head Option Code

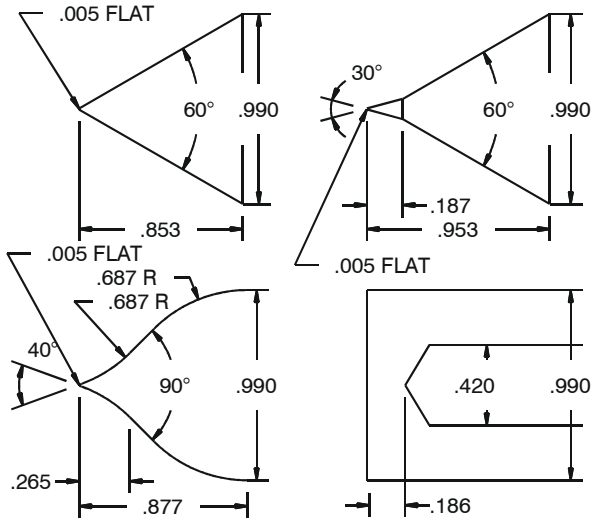

Head Diameter Options	Availability	Option Code
1.240 Diameter +/- .001	Stock	A

Product Number	A Dim.	B Dim.	Watts
GSI-1000-4.22-A90	4.22	3.72	470
GSI-1000-4.72-A90	4.72	4.22	530
GSI-1000-5.22-A90	5.22	4.72	595
GSI-1000-5.72-A90	5.72	5.22	655
GSI-1000-6.22-A90	6.22	5.72	720
GSI-1000-6.72-A90	6.72	6.22	780
GSI-1000-7.22-A90	7.22	6.72	845
GSI-1000-7.72-A90	7.72	7.22	910
GSI-1000-8.22-A90	8.22	7.72	970
GSI-1000-8.72-A90	8.72	8.22	1035
GSI-1000-9.22-A90	9.22	8.72	1095
GSI-1000-9.72-A90	9.72	9.22	1160
GSI-1000-10.22-A90	10.22	9.72	1220
GSI-1000-10.72-A90	10.72	10.22	1285
GSI-1000-11.22-A90	11.22	10.72	1350
GSI-1000-11.72-A90	11.72	11.22	1410
GSI-1000-12.22-A90	12.22	11.72	1475
GSI-1000-12.72-A90	12.72	12.22	1535
GSI-1000-13.22-A90	13.22	12.72	1600
GSI-1000-13.72-A90	13.72	13.22	1660

Lead Exit Options	Availability	Option Code
Right Angle 90 Degree Lead Exit	Stock	90
Straight Out 0 Degree Lead Exit	Stock	00